



CABLE COATING CP 679A PLUS

Product application guideline



CONTENTS

1. Basic information	3
2. Safety	3
2.1 Environmental precautions	3
3. Material storage	3
3.1 Storage temperature	3
3.2 Shelf life	3
4. Product features and approvals	4
5. Chemical resistance	4
6. Site requirements	5
6.1 Required terms	5
6.2 Application temperature	5
6.3 Recommended tools	5
7. Application / instructions for use	5
7.1 Cleaning	5
7.2 Mixing	6
7.3a Application by spray	6
7.3b Application by brush	8
7.4 Measure wet film thickness (WFT)	8
7.5 Curing time	8
7.6 Measure dry film thickness (DFT)	9
8. Damaged cable coating	9

1. BASIC INFORMATION

Hilti CP 679A Plus is an ablative fire protection cable coating that can be applied with a brush or by airless sprayers. In case of fire, the product releases crystal-bound water and absorbs heat. This allows temperature reduction through an endothermic reaction to prevent the propagation of fire along the cable. Hence, CP 679A Plus offers effective and economical cable fire protection. It is important to adhere to the following application methods to comply with the independent fire test evidence that supports the use of CP 679A Plus. The correct thickness, application and finish of the product must be assured.

2. SAFETY

Personal protective equipment (PPE):

- Protective clothing
- Safety glasses
- Gloves



Additional advice for respiratory protection:

- Ensure adequate air circulation in the workstation

Read Safety Data Sheet and Product Application Guide.

2.1 Environmental precautions

Do not discharge CP 679A Plus into drains, watercourses or soil. Consult with regulatory agencies or your corporate personnel for disposal methods that comply with local, state and federal safety, health and environmental regulations.

3. MATERIAL STORAGE

3.1 Storage temperature

Prior to use, Hilti CP 679A Plus must be kept in its original sealed containers. Hilti CP 679A Plus must be protected from direct sunlight and maintained between min. 41 °F (5 °C) to max. 86 °F (30 °C) during transportation and storage.

3.2 Shelf life

When stored properly, Hilti CP 679A Plus has a shelf life of 12 months from the date of manufacture. See label for expiry date. Do not use expired product.



4. PRODUCT FEATURES AND APPROVALS

Color	White
Chemical base	Water-based acrylic dispersion
Reaction to fire	Class E acc. EN 13501-1; Class 0 acc. BS 476 Part 6&7; Class B2 acc. DIN 4102-1
FM Approval Class 3971	DFT 1.6 mm
DNV GL acc. IEC 60332-3-22	DFT 0.5 mm, Category A: 2018 for 60 minutes
Circuit integrity IEC 60331-21	On request
Viscosity	25,000 to 40,000 [mPas]
Density	1,410 ± 70 [g/L]
Nonvolatile components	66.0 to 86.0 [%] EN ISO 3251
Volume	solids 55%
Coating flexibility	≥ 5 mm – EN ISO 1519 – Sample thickness 1.5 mm, no crack
Limiting oxygen index	55.0% ± 3% – ISO 4589 – Sample thickness 1.5 mm
Sagging	No sagging up to 2.5 mm WFT
Aging	According FM 3971 & TR 024
Saltwater	According FM 3971
Water, weather & UV resistance	According EN ISO 2812-3
Chemical resistance	According EN ISO 2812-3
Smoke density and toxicity	According DIN EN 5659-2
Flame spread index	Class Rating A: 15 According ASTM E84
Smoke developed index	Class Rating A: 60 According ASTM E84
Mold and mildew	ISO 846 (Method A)
VOC / LEED V4.1	0g/L compliant

Free of solvents and halogens, asbestos, lead, mercury, hexavalent chromium and polybrominated biphenyl

5. CHEMICAL RESISTANCE

The list of industrial chemicals below gives an overview of usability and resistance after coating dry through (min. 4 days).

Results are based on tests according to DIN EN ISO 2812-3 at 1 hour and 24 hours.

	1 hour	24 hours
Acetic acid 10%	++	+++
Nitric acid 10%	--	--
Sulfuric acid 10%	++	++
Caustic potash 10%	--	--
Ammonia 3.5%	++	+++
Tap water	++	+++
Acetone	++	++
Mineral spirit	+++	+++
Diesel	+++	+++

6. SITE REQUIREMENTS

6.1 Required terms

Prior to the application, ensure that proper services, safety and site conditions exist for the application process. These requirements will include power, ventilation, scaffolding or ladders, PPE, lighting, waste disposal, as well as a serviced airless sprayer (if applicable) and adequate spares.

6.2 Application temperature

Hilti CP 679A Plus may only be applied when the ambient and substrate temperature is between 41 °F (5 °C) and 104 °F (40 °C). The cable surface must be dry, free of dust and oil, and the surface temperature should be at least 5 °F (3 °C) above the dew point to prevent condensation from forming on the cable surface. Before, during, and for at least 24 hours after application, an ambient and substrate temperature of minimum 41 °F (5 °C) must be maintained. If required by the work schedule, the contractor should provide housing, air circulation and heat to maintain the correct temperature and humidity in the application areas.

When working in ambient/substrate temperatures above 86 °F (30 °C), it is recommended to keep the material below 86 °F (30 °C) for optimal pot life temperature. Storage of material in use as per storage temperature stated on the product label.

6.3 Recommended tools

- Adhesive tape /masking film
- Airless sprayer or brush
- Mirror as an inspection aid
- Wet comb (or similar) to measure the Wet Film Thickness (WFT).
- Metal tape, plate (or similar) when measuring the Dry Film Thickness (DFT) with commercially available electronic DFT gauges
- Electronic DFT gauge
- Drill mixer (#2333179 Hilti NMX 6-22 + #2331842 Hilti NMX-MP 120 M14)

7. APPLICATION / INSTRUCTIONS FOR USE

All areas that will not receive a coating should be masked off, typically with lightweight polyethylene plastic and masking tape.

Hilti cable coating can be applied by:

- painting by brush
- spraying by airless sprayer

7.1 Cleaning

Cable surface and support structures (if coating applied) must be dry and free of dust, grease and oil before applying a cable coating.

Cables may be cleaned in these ways:

- using a Hilti vacuum (or equivalent) to remove smaller debris from cable or cable trays
- (for outdoor application only) a water pressure cleaner may be used

Wipe down cables with a damp rag to remove dust, grease and oil from cables and cable supports.

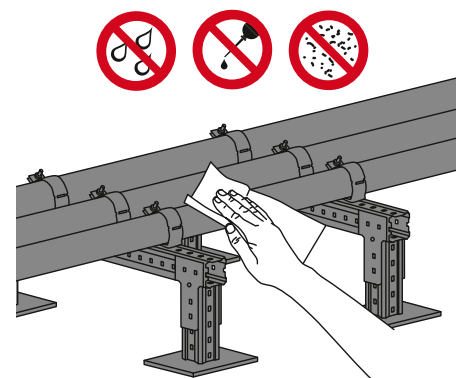

7.2 Mixing

Hilti CP 679A Plus is supplied ready to use in sealed containers and must be stirred thoroughly until homogeneous prior to use. To ensure proper mixing of the Hilti CP 679A Plus please follow the given information in the Product Application guideline. Stirring with a drill-type mixer until homogeneous for approx. 5 minutes is recommended.

Attention: Do not add water to the CP 679A Plus Cable Coating.

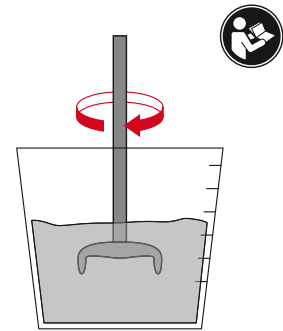

7.3a Application by spray

Refer to your airless spray unit manufacturer details to operate pump and note permit to use the airless device.

Airless spraying is the preferred application method for optimal aesthetics. Hilti CP 679A Plus can also be applied by brush for touch-ups and repair purposes, hence the correct Dry Film Thickness (DFT) must comply with the requirements of the official approval document.

1. Prepare airless spray pump

It is possible to apply CP 679A Plus by means of airless spraying. The nozzle sizes can vary depending on the pump type and manufacturer. The best aesthetic finish can be achieved with a nozzle size of 19 (0.019") or higher (>0.019"/0.48 mm), with an adjusted flow rate and pump pressure.

Hilti CP 679A Plus requires that all filters commonly found in airless sprayers are removed prior to the application. There are generally three filters:

- suction filter
- priming pump filter
- spray gun filter

If the spray nozzle has "diffuser sticks" these will also need to be removed. Leaving a mesh filter and/or diffuser sticks in the spray system will lead to the removal of some Hilti CP 679A Plus ingredients and cause blockages.

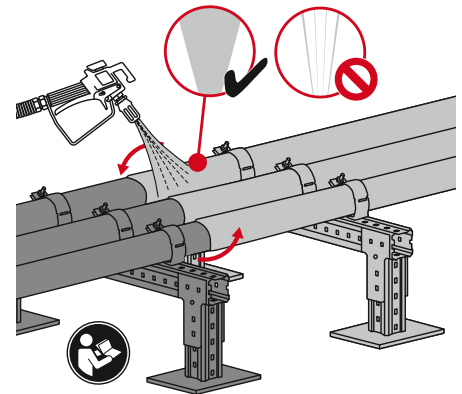

2. Spray test

A spray test is recommended prior to cable coating.

Purging the airless spray system before starting to spray will minimize tip blockages. For this reason, purging is recommended before every start-up (this process takes approx. 3–4 min).

For more precise Dry Film Thickness (DFT) measurement, the use of commercially available electronic-type gauges is recommended, hence a metal foil (per measurement) should be placed on the cables prior to spray Coating. Multiple measurements should be taken per cable to ensure the required coating thickness over the entire cable system.

3. Layer thickness and consumption

To calculate cable coating consumption, the following factors need to be considered:

- Cable length:** Determine the total length of the cable that needs to be coated. This can be measured in meters or feet.
- Coating thickness:** Defined based on followed standards (FM, IEC or local standardization). This can be measured in millimeters or inches.
- Coating density:** Hilti Cable Coating CP 679A Plus

Coating consumption in kg = Cable length × Coating thickness × Coating density

Estimated coating consumption in g/m²

Coating density	1,410 ± 70 [g/L]							
	1,000 g/m ²		2,000 g/m ²		3,200 g/m ²		4,000 g/m ²	
Coating consumption								
Wet Film Thickness (WFT)	900 μm	0.9 mm	1,800 μm	1.8 mm	2,900 μm	2.9 mm	3,600 μm	3.6 mm
DRY Film Thickness (DFT)	500 μm	0.5 mm	1,000 μm	1.0 mm	1,600 μm	1.6 mm	2,000 μm	2.0 mm

These calculations provide an estimate and the actual consumption may vary depending on factors such as the application method, coating material characteristics and the specific cable design.

In addition, material losses must be considered in the application.

4. Applying cable coating by airless pump

It is recommended to spray the cable coating from a distance of approximately 300mm away from cable, cable tray or cable support.

5. Pauses or interruptions during use

We recommend flushing the pump's fluid line and gun when the applicator has an interruption or break to prevent possible curing or clogging in the pump, followed by cleaning the tip and tip guard.

Seal the bucket to prevent skin forming after an interruption or break. Before resuming application, stir thoroughly until the product is homogeneous again.

In the event of an interruption, we recommend a material overlap of approx. 50mm in the area of the interruption.

6. Cleaning the pump

Proper cleaning of the airless spray machine is critical to prevent any material remaining in the nozzles / pumps / hoses from hardening. Clean the machine according to the manufacturer's recommendations.

7.3b Application by brush

The best results are achieved with a high-quality latex brush. Typically do not apply more than 0.5 mm WFT for the best finish and drying.

For layer thickness and coating consumption refer to section 7.3a Spray Application, step 3 “Layer thickness and consumption”.

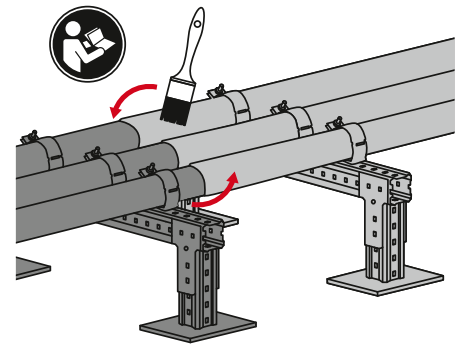

7.4 Measure wet film thickness (WFT)

During the application of CP 679A Plus cable coating, the WFT should be checked frequently with a clean Wet Film Thickness gauge by inserting the teeth into the wet cable coating on a flat surface. Care should be taken to ensure that previously applied layers have cured.



WFT can also be measured on tape wrapped on the cable prior to applying cable coating.

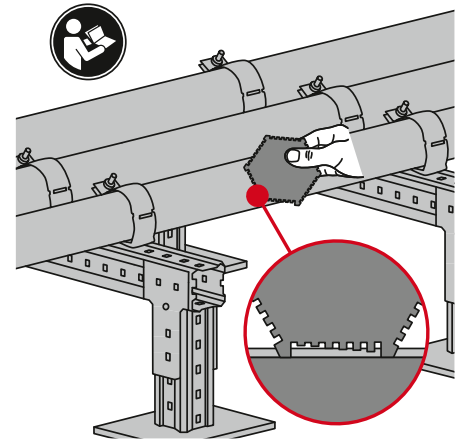

7.5 Curing time

The curing time of the coating depends on the ambient temperature, air movement, relative humidity and coating thickness. In general, when using CP 679A Plus, applicators can expect the product to dry/cure faster at higher ambient temperatures than at lower temperatures. A minimum temperature of 41 °F (5 °C) must be maintained.

Curing time at 73 °F (23 °C) and relative humidity of 65% ± 3%

Dry-to-touch time	Approx. 4 hours
Overpaint ability after	Approx. 8 hours
Full cure time	24–48 hours

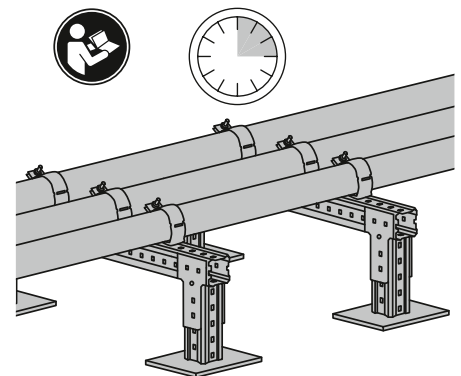

7.6 Measure dry film thickness (DFT)

The Dry Film Thickness (DFT) can be estimated from the Wet Film Thickness (WFT) by multiplying by a factor of 0.55. The actual opacity depends on the surface, the substrate, the application technique and the method.

A DFT measurement can be made when the coating is dry to allow measurement without indenting the surface. DFT can also be measured with electronic DFT gauges. Multiple measurements should be taken per cable to verify the required coating thickness over the entire cable system. The final DFT measurement can be carried out after the final coating layer has completely dried.

Verify that the total DFT of the fire protection coating complies with the requirements of the official approval document.

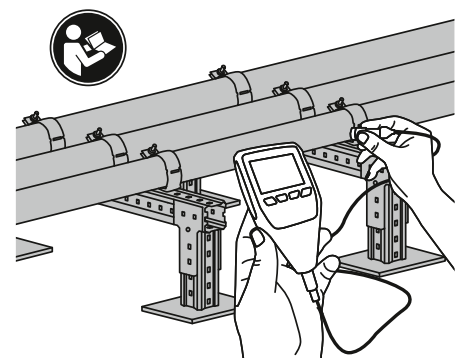

8. DAMAGED CABLE COATING

If larger areas of the cable coating have been damaged, these damaged areas can be repaired using the airless spray system. The procedure here remains the same as when the coating was first applied. The aim is to achieve the final layer thickness, Dry Film Thickness (DFT), in accordance with the approval requirements.

Minor damage can also be repaired with a brush. It is important to ensure that the required Dry Film Thickness (DFT) is achieved after the repair in accordance with the approval requirements.



For warranty reasons, please document the application conditions in accordance with local regulations or ISO 12944 points 7 and 8.



Hilti Aktiengesellschaft
9494 Schaan, Liechtenstein
P +423-234 2965

www.facebook.com/hiltigroup
www.hilti.group