

SK

## VYHLÁSENIE O PARAMETROCH

podľa prílohy III k nariadeniu (EÚ) č. 305/2011 (nariadenie o stavebných výrobkoch)

 Hilti samorezné skrutky S-MS Z, S-MS C  
 č. Hilti-SF-DoP-003

- Jedinečný identifikačný kód typu výrobku:** Hilti samorezné skrutky S-MS Z, S-MS C
- Typ, číslo výrobnej dávky alebo sériové číslo, alebo akýkoľvek iný prvok umožňujúci identifikáciu stavebného výrobku, ako sa vyžaduje podľa článku 11 ods. 4:** Typ a číslo výrobnej dávky sú uvedené na balení
- Zamýšľané použitia stavebného výrobku, ktoré uvádza výrobca, v súlade s uplatniteľnou harmonizovanou technickou špecifikáciou:**

Generický typ a použitie	Samorezné upevňovacie skrutky pre kovové prvky a opláštenie
Zahrnutá veľkosť výrobku	Priemer skrutky 4,8 mm
Základný a upevnený materiál	Oceľ podľa EN 10346 Hliníková zliatina podľa EN 485 / EN 573
Materiál upevňovacieho prvku	Pozinkovaná alebo ošetrená náterom cementovaná uhlíková oceľ podľa EN 10084
Zaťaženie	Statická a kvázistatická (zaťaženie vetrom)

- Meno, registrované obchodné meno alebo registrovaná ochranná známka a kontaktná adresa výrobcu, ako sa vyžaduje podľa článku 11 ods. 5:** Hilti Aktiengesellschaft, Business Unit Direct Fastening, 9494 Schaan, Fürstentum Liechtenstein
- V prípade potreby meno a kontaktná adresa splnomocneného zástupcu, ktorého splnomocnenie zahŕňa úlohy vymedzené v článku 12 ods. 2:** nevzťahuje sa
- Systém alebo systémy posudzovania a overovania nemennosti parametrov stavebného výrobku, ako sa uvádzajú v prílohe V:** systém 2+
- V prípade vyhlásenie o parametroch týkajúceho sa stavebného výrobku, na ktorý sa vzťahuje harmonizovaná norma:** nevzťahuje sa
- V prípade vyhlásenia o parametroch týkajúceho sa stavebného výrobku, na ktorý bolo vypracované európske technické posúdenie:**  
ETA-10/0182 vydané na základe EAD 330046-01-0602. Notifikovaná osoba MPA-Karlsruhe 0769 vykonala úlohy tretej strany v systéme 2+ a vydala certifikát zhody systému riadenia výroby.

### 9. Deklarované parametre:

Základné charakteristiky	Parametre	Harmonizovaná technická špecifikácia
Charakteristická únosnosť v ťahu $N_{R,k}$	Príloha 1 - 6 ETA-10/0182 (Príloha 4 – 9)	ETA-10/0182 EAD 330046-01-0602
Charakteristická únosnosť v šmyku $V_{R,k}$		
Typ pripojenia		
Aplikačné limity		
Reakcia na oheň	A1	

- Parametre výrobku uvedené v bodoch 1 a 2 sú v zhode s deklarovými parametrami v bode 9. Toto vyhlásenie o parametroch sa vydáva na výhradnú zodpovednosť výrobcu uvedeného v bode 4.**

Podpísal(-a) za a v mene výrobcu:

**Lars Taenzer**  
 Head of Business Unit Direct Fastening



**Pierre Hohmeier**  
 Head of Quality Screw Fastening

Hilti Aktiengesellschaft, Schaan, 03.05.2019

Annex 1:  
ETA-10/0182, Annex 4

**Material:**

Fastener: carbon steel, case hardened and galvanized or coated

Washer: none

Component I: S280GD, S320GD, S350GD - EN 10346

Component II: S280GD, S320GD, S350GD - EN 10346

---

**Drilling capacity:**  $\Sigma t_i \leq 2,50$  mm

---

**Timber substructures:**  
no performance determined

t [mm]	t <sub>i</sub> [mm]								
	0,50	0,55	0,63	0,75	0,88	1,00	1,13	1,25	
V <sub>0,x</sub> [kN]	0,50	1,29	1,37	1,51	1,71	1,71	1,71	1,71	1,71
	0,55	1,29	1,54	1,65	1,82	1,82	1,82	1,82	2,05
	0,63	1,29	1,54	1,80	2,00	2,00	2,00	2,00	2,59
	0,75	1,29	1,54	1,80	2,27	2,27	2,27	2,84	3,40
	0,88	1,29	1,54	1,80	2,27	2,96	2,96	2,96	3,40
	1,00	1,29	1,54	1,80	2,27	2,96	3,64	3,64	3,64
	1,13	1,29	1,54	1,80	2,27	2,96	3,64	3,87	3,87
	1,25	1,29	1,54	1,80	2,27	2,96	3,64	3,87	4,10
	1,50	1,29	1,54	1,80	2,27	2,96	3,64	—	—
	1,75	1,29	1,54	1,80	2,27	—	—	—	—
	2,00	1,29	—	—	—	—	—	—	—
N <sub>0,x</sub> [kN]	0,50	0,76	0,87	1,04	1,29	1,56	1,82	1,93	1,93
	0,55	0,76	0,87	1,04	1,29	1,56	1,82	2,09	2,25
	0,63	0,76	0,87	1,04	1,29	1,56	1,82	2,09	2,34
	0,75	0,76	0,87	1,04	1,29	1,56	1,82	2,09	2,34
	0,88	0,76	0,87	1,04	1,29	1,56	1,82	2,09	2,34
	1,00	0,76	0,87	1,04	1,29	1,56	1,82	2,09	2,34
	1,13	0,76	0,87	1,04	1,29	1,56	1,82	2,09	2,34
	1,25	0,76	0,87	1,04	1,29	1,56	1,82	2,09	2,34
	1,50	0,76	0,87	1,04	1,29	1,56	1,82	—	—
	1,75	0,76	0,87	1,04	1,29	—	—	—	—
	2,00	0,76	—	—	—	—	—	—	—
M <sub>0,perm</sub> [Nm]									

No additional regulations.

Self piercing screw	Annex 4
Hilti S-MS 01 Z 4,8 x L Hilti S-MS 01 C 4,8 x L with hexagon head	

Annex 2:  
ETA-10/0182, Annex 5

	<p><b>Material:</b></p> <p><b>Fastener:</b> carbon steel, case hardened and galvanized or coated</p> <p><b>Washer:</b> carbon steel, galvanized or coated stainless Steel (1.4301) - EN 10088</p> <p><b>Component I:</b> S280GD, S320GD, S350GD - EN 10346</p> <p><b>Component II:</b> S280GD, S320GD, S350GD - EN 10346</p>																																																																																																																																																																																																																																																																																																																																													
	<p><b>Drilling capacity:</b> <math>\Sigma t_i \leq 2,50</math> mm</p>																																																																																																																																																																																																																																																																																																																																													
<p><b>Timber substructures:</b> no performance determined</p>																																																																																																																																																																																																																																																																																																																																														
<table border="1"> <thead> <tr> <th rowspan="2"></th> <th rowspan="2"><math>t_i</math> [mm]</th> <th colspan="12"><math>t_i</math> [mm]</th> </tr> <tr> <th>0,40</th><th>0,50</th><th>0,55</th><th>0,63</th><th>0,75</th><th>0,88</th><th>1,00</th><th>1,25</th> <th>0,40</th><th>0,50</th><th>0,55</th><th>0,63</th><th>0,75</th><th>0,88</th><th>1,00</th><th>1,25</th> </tr> </thead> <tbody> <tr> <td rowspan="8"><math>V_{Rk}</math> [kN]</td> <td>0,40</td><td>0,81</td><td>0,87</td><td>0,90</td><td>0,95</td><td>1,03</td><td>1,03</td><td>1,03</td><td>1,03</td><td>1,03</td><td>1,03</td><td>1,03</td><td>1,03</td><td>1,03</td><td>1,03</td><td>1,03</td><td>1,03</td> </tr> <tr> <td>0,50</td><td>0,81</td><td>1,01</td><td>1,01</td><td>1,02</td><td>1,03</td><td>1,03</td><td>1,03</td><td>1,03</td><td>1,03</td><td>1,03</td><td>1,03</td><td>1,03</td><td>1,03</td><td>1,03</td><td>1,03</td><td>1,03</td> </tr> <tr> <td>0,55</td><td>0,81</td><td>1,01</td><td>1,26</td><td>1,26</td><td>1,26</td><td>1,26</td><td>1,26</td><td>1,26</td><td>1,26</td><td>1,26</td><td>1,26</td><td>1,26</td><td>1,26</td><td>1,26</td><td>1,26</td><td>1,26</td> </tr> <tr> <td>0,63</td><td>0,81</td><td>1,01</td><td>1,26</td><td>1,66</td><td>1,66</td><td>1,66</td><td>1,66</td><td>1,66</td><td>1,66</td><td>1,66</td><td>1,66</td><td>1,66</td><td>1,66</td><td>1,66</td><td>1,66</td><td>1,66</td> </tr> <tr> <td>0,75</td><td>0,81</td><td>1,01</td><td>1,26</td><td>1,66</td><td>2,26</td><td>2,26</td><td>2,26</td><td>2,26</td><td>2,26</td><td>2,26</td><td>2,26</td><td>2,26</td><td>2,26</td><td>2,26</td><td>2,26</td><td>2,26</td> </tr> <tr> <td>0,88</td><td>0,81</td><td>1,01</td><td>1,26</td><td>1,66</td><td>2,26</td><td>2,77</td><td>2,77</td><td>2,77</td><td>2,77</td><td>2,77</td><td>2,77</td><td>2,77</td><td>2,77</td><td>2,77</td><td>2,77</td><td>2,77</td> </tr> <tr> <td>1,00</td><td>0,81</td><td>1,01</td><td>1,26</td><td>1,66</td><td>2,26</td><td>2,77</td><td>3,24</td><td>3,24</td><td>3,24</td><td>3,24</td><td>3,24</td><td>3,24</td><td>3,24</td><td>3,24</td><td>3,24</td><td>3,24</td> </tr> <tr> <td>1,25</td><td>0,81</td><td>1,01</td><td>1,26</td><td>1,66</td><td>2,26</td><td>2,77</td><td>3,24</td><td>4,24</td><td>4,24</td><td>4,24</td><td>4,24</td><td>4,24</td><td>4,24</td><td>4,24</td><td>4,24</td><td>4,24</td> </tr> <tr> <td rowspan="8"><math>N_{Rk}</math> [kN]</td> <td>0,40</td><td>0,46</td><td>0,76</td><td>0,88</td><td>1,03</td><td>1,27</td><td>1,43</td><td>1,43</td><td>1,43</td><td>1,43</td><td>1,43</td><td>1,43</td><td>1,43</td><td>1,43</td><td>1,43</td><td>1,43</td><td>1,43</td> </tr> <tr> <td>0,50</td><td>0,46</td><td>0,76</td><td>0,88</td><td>1,03</td><td>1,27</td><td>1,60</td><td>1,80</td><td>1,80</td><td>1,80</td><td>1,80</td><td>1,80</td><td>1,80</td><td>1,80</td><td>1,80</td><td>1,80</td><td>1,80</td> </tr> <tr> <td>0,55</td><td>0,46</td><td>0,76</td><td>0,88</td><td>1,03</td><td>1,27</td><td>1,60</td><td>1,90</td><td>1,90</td><td>1,90</td><td>1,90</td><td>1,90</td><td>1,90</td><td>1,90</td><td>1,90</td><td>1,90</td><td>1,90</td> </tr> <tr> <td>0,63</td><td>0,46</td><td>0,76</td><td>0,88</td><td>1,03</td><td>1,27</td><td>1,60</td><td>1,90</td><td>2,34</td><td>2,34</td><td>2,34</td><td>2,34</td><td>2,34</td><td>2,34</td><td>2,34</td><td>2,34</td><td>2,34</td> </tr> <tr> <td>0,75</td><td>0,46</td><td>0,76</td><td>0,88</td><td>1,03</td><td>1,27</td><td>1,60</td><td>1,90</td><td>2,49</td><td>2,49</td><td>2,49</td><td>2,49</td><td>2,49</td><td>2,49</td><td>2,49</td><td>2,49</td><td>2,49</td> </tr> <tr> <td>0,88</td><td>0,46</td><td>0,76</td><td>0,88</td><td>1,03</td><td>1,27</td><td>1,60</td><td>1,90</td><td>2,49</td><td>2,49</td><td>2,49</td><td>2,49</td><td>2,49</td><td>2,49</td><td>2,49</td><td>2,49</td><td>2,49</td> </tr> <tr> <td>1,00</td><td>0,46</td><td>0,76</td><td>0,88</td><td>1,03</td><td>1,27</td><td>1,60</td><td>1,90</td><td>2,49</td><td>2,49</td><td>2,49</td><td>2,49</td><td>2,49</td><td>2,49</td><td>2,49</td><td>2,49</td><td>2,49</td> </tr> <tr> <td>1,25</td><td>0,46</td><td>0,76</td><td>0,88</td><td>1,03</td><td>1,27</td><td>1,60</td><td>1,90</td><td>2,49</td><td>2,49</td><td>2,49</td><td>2,49</td><td>2,49</td><td>2,49</td><td>2,49</td><td>2,49</td><td>2,49</td> </tr> <tr> <td><math>M_{Rk}</math> [Nm]</td> <td></td><td></td><td></td><td></td><td></td><td></td><td></td><td></td><td></td><td></td><td></td><td></td><td></td><td></td><td></td><td></td><td></td> </tr> </tbody> </table>														$t_i$ [mm]	$t_i$ [mm]												0,40	0,50	0,55	0,63	0,75	0,88	1,00	1,25	0,40	0,50	0,55	0,63	0,75	0,88	1,00	1,25	$V_{Rk}$ [kN]	0,40	0,81	0,87	0,90	0,95	1,03	1,03	1,03	1,03	1,03	1,03	1,03	1,03	1,03	1,03	1,03	1,03	0,50	0,81	1,01	1,01	1,02	1,03	1,03	1,03	1,03	1,03	1,03	1,03	1,03	1,03	1,03	1,03	1,03	0,55	0,81	1,01	1,26	1,26	1,26	1,26	1,26	1,26	1,26	1,26	1,26	1,26	1,26	1,26	1,26	1,26	0,63	0,81	1,01	1,26	1,66	1,66	1,66	1,66	1,66	1,66	1,66	1,66	1,66	1,66	1,66	1,66	1,66	0,75	0,81	1,01	1,26	1,66	2,26	2,26	2,26	2,26	2,26	2,26	2,26	2,26	2,26	2,26	2,26	2,26	0,88	0,81	1,01	1,26	1,66	2,26	2,77	2,77	2,77	2,77	2,77	2,77	2,77	2,77	2,77	2,77	2,77	1,00	0,81	1,01	1,26	1,66	2,26	2,77	3,24	3,24	3,24	3,24	3,24	3,24	3,24	3,24	3,24	3,24	1,25	0,81	1,01	1,26	1,66	2,26	2,77	3,24	4,24	4,24	4,24	4,24	4,24	4,24	4,24	4,24	4,24	$N_{Rk}$ [kN]	0,40	0,46	0,76	0,88	1,03	1,27	1,43	1,43	1,43	1,43	1,43	1,43	1,43	1,43	1,43	1,43	1,43	0,50	0,46	0,76	0,88	1,03	1,27	1,60	1,80	1,80	1,80	1,80	1,80	1,80	1,80	1,80	1,80	1,80	0,55	0,46	0,76	0,88	1,03	1,27	1,60	1,90	1,90	1,90	1,90	1,90	1,90	1,90	1,90	1,90	1,90	0,63	0,46	0,76	0,88	1,03	1,27	1,60	1,90	2,34	2,34	2,34	2,34	2,34	2,34	2,34	2,34	2,34	0,75	0,46	0,76	0,88	1,03	1,27	1,60	1,90	2,49	2,49	2,49	2,49	2,49	2,49	2,49	2,49	2,49	0,88	0,46	0,76	0,88	1,03	1,27	1,60	1,90	2,49	2,49	2,49	2,49	2,49	2,49	2,49	2,49	2,49	1,00	0,46	0,76	0,88	1,03	1,27	1,60	1,90	2,49	2,49	2,49	2,49	2,49	2,49	2,49	2,49	2,49	1,25	0,46	0,76	0,88	1,03	1,27	1,60	1,90	2,49	2,49	2,49	2,49	2,49	2,49	2,49	2,49	2,49	$M_{Rk}$ [Nm]																	
	$t_i$ [mm]	$t_i$ [mm]																																																																																																																																																																																																																																																																																																																																												
		0,40	0,50	0,55	0,63	0,75	0,88	1,00	1,25	0,40	0,50	0,55	0,63	0,75	0,88	1,00	1,25																																																																																																																																																																																																																																																																																																																													
$V_{Rk}$ [kN]	0,40	0,81	0,87	0,90	0,95	1,03	1,03	1,03	1,03	1,03	1,03	1,03	1,03	1,03	1,03	1,03	1,03																																																																																																																																																																																																																																																																																																																													
	0,50	0,81	1,01	1,01	1,02	1,03	1,03	1,03	1,03	1,03	1,03	1,03	1,03	1,03	1,03	1,03	1,03																																																																																																																																																																																																																																																																																																																													
	0,55	0,81	1,01	1,26	1,26	1,26	1,26	1,26	1,26	1,26	1,26	1,26	1,26	1,26	1,26	1,26	1,26																																																																																																																																																																																																																																																																																																																													
	0,63	0,81	1,01	1,26	1,66	1,66	1,66	1,66	1,66	1,66	1,66	1,66	1,66	1,66	1,66	1,66	1,66																																																																																																																																																																																																																																																																																																																													
	0,75	0,81	1,01	1,26	1,66	2,26	2,26	2,26	2,26	2,26	2,26	2,26	2,26	2,26	2,26	2,26	2,26																																																																																																																																																																																																																																																																																																																													
	0,88	0,81	1,01	1,26	1,66	2,26	2,77	2,77	2,77	2,77	2,77	2,77	2,77	2,77	2,77	2,77	2,77																																																																																																																																																																																																																																																																																																																													
	1,00	0,81	1,01	1,26	1,66	2,26	2,77	3,24	3,24	3,24	3,24	3,24	3,24	3,24	3,24	3,24	3,24																																																																																																																																																																																																																																																																																																																													
	1,25	0,81	1,01	1,26	1,66	2,26	2,77	3,24	4,24	4,24	4,24	4,24	4,24	4,24	4,24	4,24	4,24																																																																																																																																																																																																																																																																																																																													
$N_{Rk}$ [kN]	0,40	0,46	0,76	0,88	1,03	1,27	1,43	1,43	1,43	1,43	1,43	1,43	1,43	1,43	1,43	1,43	1,43																																																																																																																																																																																																																																																																																																																													
	0,50	0,46	0,76	0,88	1,03	1,27	1,60	1,80	1,80	1,80	1,80	1,80	1,80	1,80	1,80	1,80	1,80																																																																																																																																																																																																																																																																																																																													
	0,55	0,46	0,76	0,88	1,03	1,27	1,60	1,90	1,90	1,90	1,90	1,90	1,90	1,90	1,90	1,90	1,90																																																																																																																																																																																																																																																																																																																													
	0,63	0,46	0,76	0,88	1,03	1,27	1,60	1,90	2,34	2,34	2,34	2,34	2,34	2,34	2,34	2,34	2,34																																																																																																																																																																																																																																																																																																																													
	0,75	0,46	0,76	0,88	1,03	1,27	1,60	1,90	2,49	2,49	2,49	2,49	2,49	2,49	2,49	2,49	2,49																																																																																																																																																																																																																																																																																																																													
	0,88	0,46	0,76	0,88	1,03	1,27	1,60	1,90	2,49	2,49	2,49	2,49	2,49	2,49	2,49	2,49	2,49																																																																																																																																																																																																																																																																																																																													
	1,00	0,46	0,76	0,88	1,03	1,27	1,60	1,90	2,49	2,49	2,49	2,49	2,49	2,49	2,49	2,49	2,49																																																																																																																																																																																																																																																																																																																													
	1,25	0,46	0,76	0,88	1,03	1,27	1,60	1,90	2,49	2,49	2,49	2,49	2,49	2,49	2,49	2,49	2,49																																																																																																																																																																																																																																																																																																																													
$M_{Rk}$ [Nm]																																																																																																																																																																																																																																																																																																																																														
<p>If both components I and II are made of S320GD or S350GD the grey highlighted values may be increased by 8,0%.</p>																																																																																																																																																																																																																																																																																																																																														
<p>Self piercing screw</p> <p>Hilti S-MS 41 Z 4,8 x L Hilti S-MS 41 C 4,8 x L Hilti S-MS 51 Z 4,8 x L Hilti S-MS 51 C 4,8 x L with hexagon head and sealing washer <math>\geq \varnothing 14</math> mm</p>											<p>Annex 5</p>																																																																																																																																																																																																																																																																																																																																			

Annex 3:  
ETA-10/0182, Annex 6

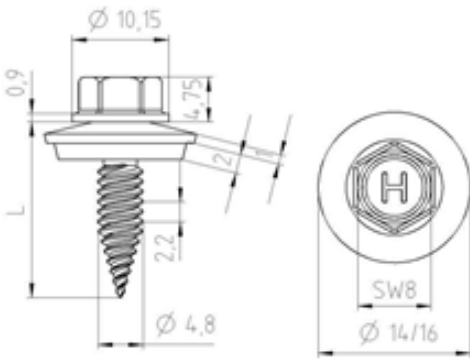

**Material:**

**Fastener:** carbon steel, case hardened and galvanized or coated

**Washer:** carbon steel, galvanized or coated  
stainless Steel (1.4301) - EN 10088

**Component I:** aluminium alloy with  $R_{m,min} = 215 \text{ N/mm}^2$  - EN 573

**Component II:** aluminium alloy with  $R_{m,min} = 215 \text{ N/mm}^2$  - EN 573

---

**Drilling capacity:**  $\Sigma t_i \leq 2,50 \text{ mm}$

---

**Timber substructures:**  
no performance determined

t [mm]	t <sub>i</sub> [mm]						
	0,50	0,60	0,70	0,80	1,00	1,20	
V <sub>rel,k</sub> [kN]	0,50	0,71	0,71	0,71	0,71	0,71	0,71
	0,60	0,71	0,92	0,92	0,92	0,92	0,92
	0,70	0,71	0,92	1,14	1,14	1,14	1,14
	0,80	0,71	0,92	1,14	1,35	1,35	1,35
	1,00	0,71	0,92	1,14	1,35	1,88	1,88
	1,20	0,71	0,92	1,14	1,35	1,88	2,28
N <sub>s,k</sub> [kN]	0,50	0,35	0,49	0,52	0,52	0,52	0,52
	0,60	0,35	0,49	0,63	0,63	0,63	0,63
	0,70	0,35	0,49	0,63	0,73	0,73	0,73
	0,80	0,35	0,49	0,63	0,77	0,84	0,84
	1,00	0,35	0,49	0,63	0,77	1,00	1,05
	1,20	0,35	0,49	0,63	0,77	1,00	1,26
N <sub>R,ilk</sub> [kN]	0,35	0,49	0,63	0,77	1,00	1,29	
M <sub>torq,m</sub> [Nm]							

The pull-through-capacities of the grey highlighted values N<sub>s,k</sub> have been determined according to EN 1999-1-4:2007 section 8.3.3.1 by calculation. This values N<sub>s,k</sub> may be increased by 6,9% when using the type „S-MS 5x“.

Self piercing screw	
Hilti S-MS 41 Z 4,8 x L Hilti S-MS 41 C 4,8 x L Hilti S-MS 51 Z 4,8 x L Hilti S-MS 51 C 4,8 x L with hexagon head and sealing washer $\geq \varnothing 14 \text{ mm}$	Annex 6

Annex 4:  
ETA-10/0182, Annex 7

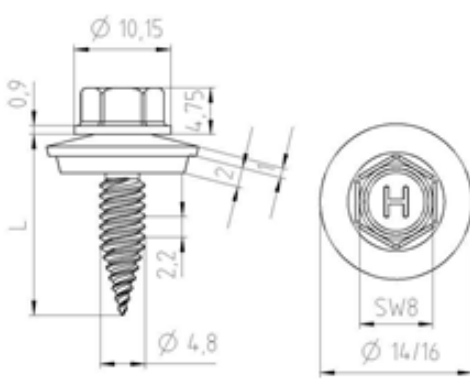

**Material:**

Fastener: carbon steel, case hardened and galvanized or coated

Washer: carbon steel, galvanized or coated stainless Steel (1.4301) - EN 10088

Component I: aluminium alloy with  $R_{m,min} = 165 \text{ N/mm}^2$  - EN 573

Component II: aluminium alloy with  $R_{m,min} = 165 \text{ N/mm}^2$  - EN 573

---

**Drilling capacity:**  $\Sigma t_i \leq 2,50 \text{ mm}$

---

**Timber substructures:**  
no performance determined

t [mm]	t <sub>i</sub> [mm]						
	0,50	0,60	0,70	0,80	1,00	1,20	
V <sub>rel</sub> [kN]	0,50	0,55	0,55	0,55	0,55	0,55	0,55
	0,60	0,55	0,71	0,71	0,71	0,71	0,71
	0,70	0,55	0,71	0,88	0,88	0,88	0,88
	0,80	0,55	0,71	0,88	1,04	1,04	1,04
	1,00	0,55	0,71	0,88	1,04	1,44	1,44
	1,20	0,55	0,71	0,88	1,04	1,44	1,83
N <sub>2,x</sub> [kN]	0,50	0,27	0,38	0,40	0,40	0,40	0,40
	0,60	0,27	0,38	0,48	0,48	0,48	0,48
	0,70	0,27	0,38	0,48	0,56	0,56	0,56
	0,80	0,27	0,38	0,48	0,59	0,64	0,64
	1,00	0,27	0,38	0,48	0,59	0,76	0,80
	1,20	0,27	0,38	0,48	0,59	0,76	0,98
N <sub>2,lik</sub> [kN]	0,27	0,38	0,48	0,59	0,76	1,03	
M <sub>1,10m</sub> [Nm]							

The pull-through-capacities of the grey highlighted values  $N_{2,x}$  have been determined according to EN 1999-1-4:2007 section 8.3.3.1 by calculation. This values  $N_{2,x}$  may be increased by 6,9% when using the type „S-MS 5x“.

Self piercing screw	Annex 7
Hilti S-MS 41 Z 4,8 x L Hilti S-MS 41 C 4,8 x L Hilti S-MS 51 Z 4,8 x L Hilti S-MS 51 C 4,8 x L with hexagon head and sealing washer $\geq \text{Ø}14 \text{ mm}$	

Annex 5:  
ETA-10/0182, Annex 8

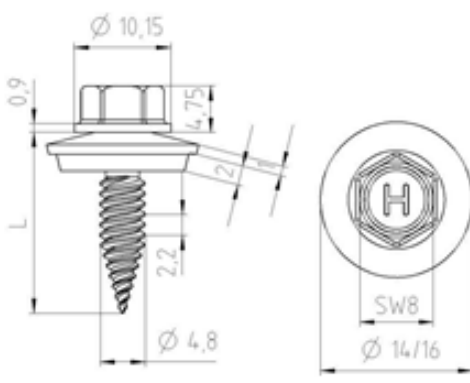

**Material:**

Fastener: carbon steel, case hardened and galvanized or coated

Washer: carbon steel, galvanized or coated stainless Steel (1.4301) - EN 10088

Component I: aluminium alloy with  $R_{m,min} = 215 \text{ N/mm}^2$  - EN 573

Component II: S280GD, S320GD, S350GD - EN 10346

**Drilling capacity:**  $\Sigma t_i \leq 2,50 \text{ mm}$

**Timber substructures:**  
no performance determined

t [mm]	t <sub>i</sub> [mm]							
	0,50	0,55	0,63	0,75	0,88	1,00	1,25	
V <sub>FeK</sub> [kN]	0,50	0,71	0,71	0,71	0,71	0,71	0,71	
	0,60	0,71	0,71	0,92	0,92	0,92	0,92	
	0,70	0,71	0,71	0,92	1,14	1,14	1,14	
	0,80	0,71	0,71	0,92	1,14	1,35	1,35	
	1,00	0,71	0,71	0,92	1,14	1,35	1,88	
	1,20	0,71	0,71	0,92	1,14	1,35	1,88	
N <sub>2,x</sub> [kN]	0,50	0,52	0,52	0,52	0,52	0,52	0,52	
	0,60	0,63	0,63	0,63	0,63	0,63	0,63	
	0,70	0,73	0,73	0,73	0,73	0,73	0,73	
	0,80	0,76	0,84	0,84	0,84	0,84	0,84	
	1,00	0,76	0,87	1,04	1,05	1,05	1,05	
	1,20	0,76	0,87	1,04	1,26	1,26	1,26	
N <sub>2,ilk</sub> [kN]	0,76	0,87	1,04	1,28	1,58	1,86	2,42	
M <sub>2,perm</sub> [Nm]								

The pull-through-capacities of the grey highlighted values  $N_{2,x}$  have been determined according to EN 1999-1-4:2007 section 8.3.3.1 by calculation. This values  $N_{2,x}$  may be increased by 6,9% when using the type „S-MS 5x“.

Self piercing screw		Annex 8
Hilti S-MS 41 Z 4,8 x L Hilti S-MS 41 C 4,8 x L Hilti S-MS 51 Z 4,8 x L Hilti S-MS 51 C 4,8 x L with hexagon head and sealing washer $\geq \varnothing 14 \text{ mm}$		

Annex 6:  
ETA-10/0182, Annex 9

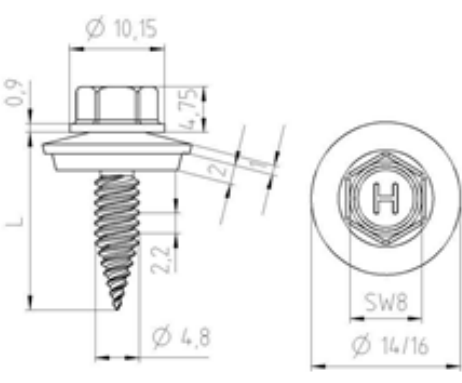

**Material:**

Fastener: carbon steel, case hardened and galvanized or coated

Washer: carbon steel, galvanized or coated stainless Steel (1.4301) - EN 10088

Component I: aluminium alloy with  $R_{m,min} = 165 \text{ N/mm}^2$  - EN 573

Component II: S280GD, S320GD, S350GD - EN 10346

---

**Drilling capacity:**  $\Sigma t_i \leq 2,50 \text{ mm}$

---

**Timber substructures:**  
no performance determined

t [mm]	t <sub>i</sub> [mm]							
	0,50	0,55	0,63	0,75	0,88	1,00	1,25	
V <sub>rel</sub> [kN]	0,50	0,55	0,55	0,55	0,55	0,55	0,55	0,55
	0,60	0,55	0,55	0,71	0,71	0,71	0,71	0,71
	0,70	0,55	0,55	0,71	0,88	0,88	0,88	0,88
	0,80	0,55	0,55	0,71	0,88	1,04	1,04	1,04
	1,00	0,55	0,55	0,71	0,88	1,04	1,44	1,44
	1,20	0,55	0,55	0,71	0,88	1,04	1,44	1,83
N <sub>ex</sub> [kN]	0,50	0,40	0,40	0,40	0,40	0,40	0,40	0,40
	0,60	0,48	0,48	0,48	0,48	0,48	0,48	0,48
	0,70	0,58	0,58	0,58	0,58	0,58	0,58	0,58
	0,80	0,64	0,64	0,64	0,64	0,64	0,64	0,64
	1,00	0,78	0,80	0,80	0,80	0,80	0,80	0,80
	1,20	0,78	0,87	0,96	0,96	0,96	0,96	0,96
N <sub>R,lik</sub> [kN]	0,76	0,87	1,04	1,28	1,58	1,86	2,42	
M <sub>LR,ex</sub> [Nm]								

The pull-through-capacities of the grey highlighted values  $N_{R,k}$  have been determined according to EN 1999-1-4:2007 section 8.3.3.1 by calculation. This values  $N_{R,k}$  may be increased by 6,9% when using the type „S-MS 5x“.

Self piercing screw		Annex 9
Hilti S-MS 41 Z 4,8 x L Hilti S-MS 41 C 4,8 x L Hilti S-MS 51 Z 4,8 x L Hilti S-MS 51 C 4,8 x L with hexagon head and sealing washer $\geq \text{Ø}14 \text{ mm}$		